

COMMERCIAL GAS WATER HEATERS

MODELS UG65, UG73

I.D.	Part #	Description	For Use With Models	Pg	I.D.	Part #	Description	For Use With Models	Pg
1	56214106-A	Aquastat	all	11	14	25004111-A	Cleanout cover	all	11
	GCN11000	Aquastat	all		15	GA1N1110	Cleanout gasket	all	11
2	95000001-A	On/off switch	all	11	16	16000008-A	Inlet/outlet nipple	all	12
3	FU7N0000	Fuse 2 amps	all	11	17	SV0N3030	T&P relief valve	UG65	12
4	94000000-A	LED circuit board	all	11		SV0N3020	T&P relief valve	UG73	
5	ETN40000	Transfor mer	all	11	18	16000009-A	Nipple	UG65	12
6	57000019-A	Pilot module	all	11		NP022241	Nipple	UG73	
7	58000006-A	Ignition wire	all	11	19	MS145410	Magnesium anode rod	all	13
8	57000018-A	Pilot/spark assembly	all	11	20	06000042-A	Flue baffle	all	11
	PTN10000	Pilot/ignitor assembly	all		21	99000008-A	Vent damper paddle 5"	UG73-125	11
9	67000001-A	Pilot tube	all	11		99000018-A	Vent damper paddle 6"	UG73	
10	56214107-A	Gas control	all	11		99000028-A	Vent damper paddle 8"	UG65	
	GCN12000	Gas control	all		22	06000000-A	Vent damper assembly 5"	UG73-125	11
11	BR5N6000	Burner	all	11		GP9N5000	Vent damper assembly 6"	UG73	
12	DV3Z0070	Brass drain valve	all	12		GP9N5001	Vent damper assembly 8"	UG65	
13	99000060-A	Access door	all	6	23	GP3N5000	Vent damper motor	all	11

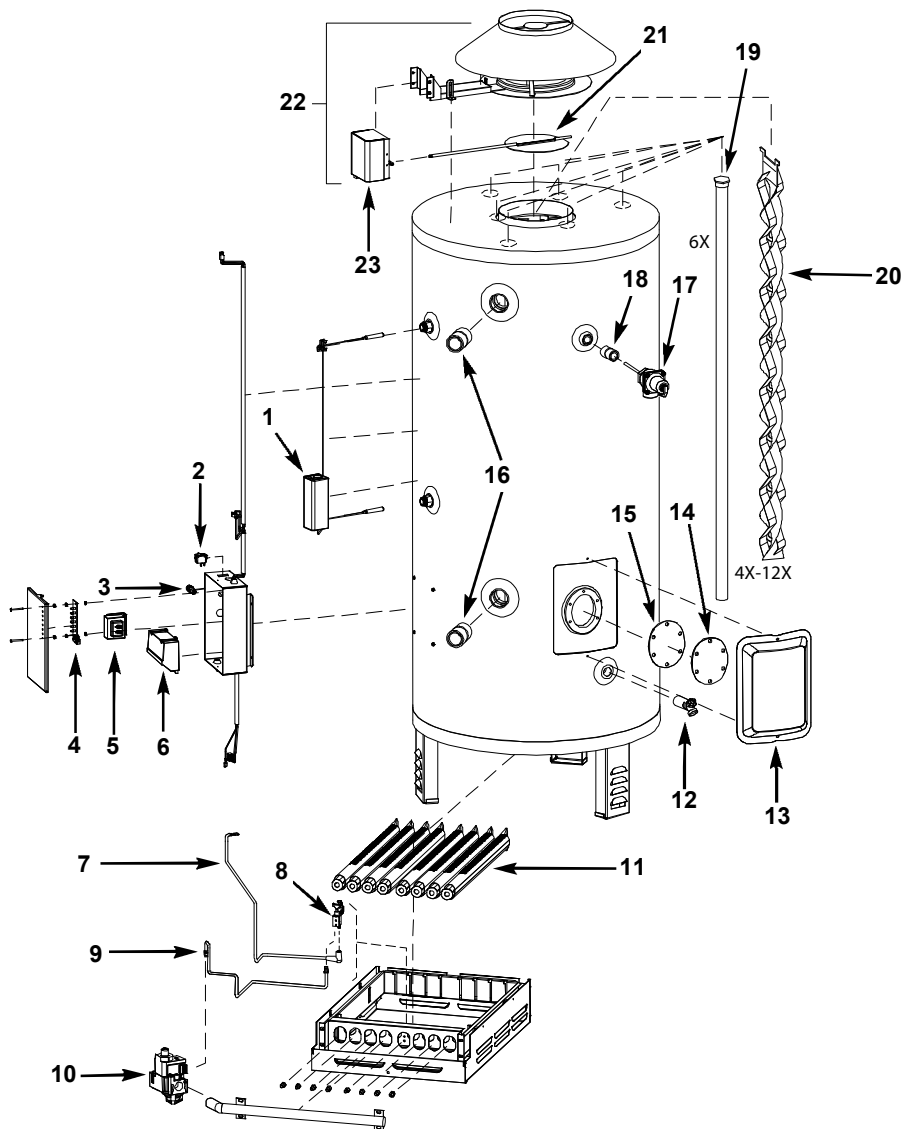

REPLACEMENT PARTS LIST

