

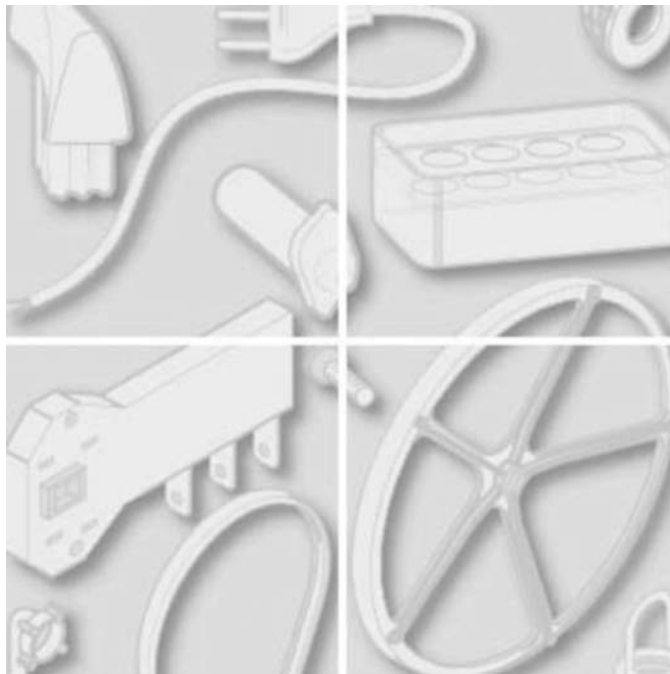

ARISTON

REPAIR PART DIAGRAMS



PRODUCT: DISHWASHER

MODEL: LI 670 B



DOOR ASSEMBLY

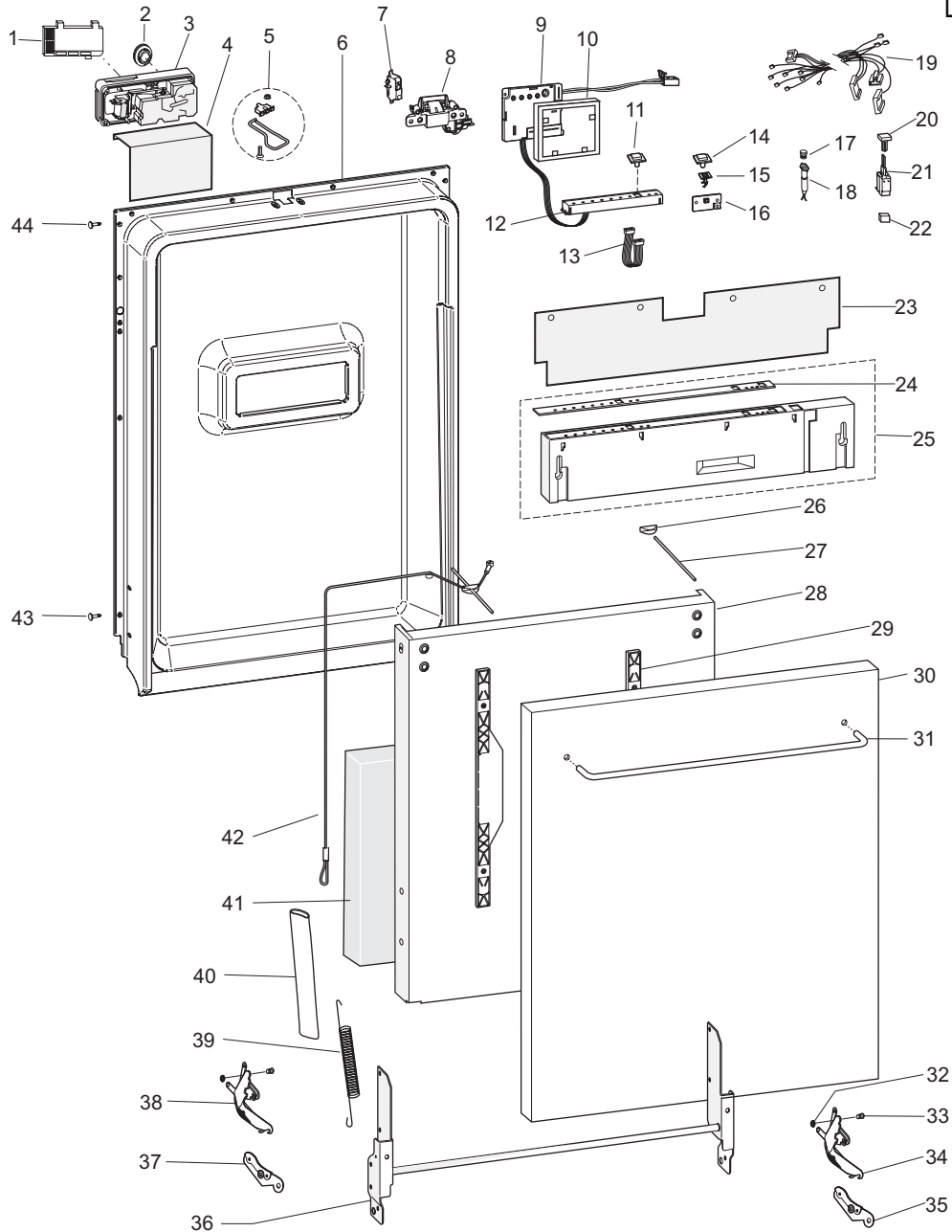

Item	Part #	Description	Item	Part #	Description
1	098134	Door, Detergent Dispenser	23	111617	Shield, Control Panel
2	051755	Cap, Rinse Agent	24	111749	Insert, Control Panel
3	111619	Detergent Dispenser Assembly	25	111644	Control Panel
4	111618	Plastic Shield	26	054933	Spring Adjustment
5	085024	Door Latch	27	055000	Spring Screw
6	095276	Inner Door (SS)	28	095269	Door Panel
7	085358	Door Switch	29	087431	Adhesive Strip, Door Panel
8	094128	Door Locking Assembly	30	112345	Outer Door (BK)
9	111575	Control Unit w/ NTC	31	112347	Door Handle (BK)
10	108957	Bracket, Control Unit	32	058776	Washer
11	085481	Button, Program	33	048504	Hinge Pin
12	095284	Program Sequence Controller	34	085017	Hinge, Right
13	087051	Ribbon Cable	35	085016	Hinge Cam, Right
14	086489	Button, Extra Dry	36	085014	Bracket, Door Hinge
15	085482	Post	37	085015	Hinge Cam, Left
16	111625	Control Board, Extra Dry	38	085018	Hinge, Left
17	100524	Lamp Lens, Red	39	086467	Door Spring
18	111622	On / Off Lamp	40	066426	Spring Sleeve
19	111623	Wire Harness	41	095273	Door Spacer
20	053468	On / Off Button	42	054936	Cable, Spring Adjustment
21	111642	On / Off Switch	43	094141	Screw, Door Panel
22	095278	Terminal Protection	44	094120	Screw, Control Panel

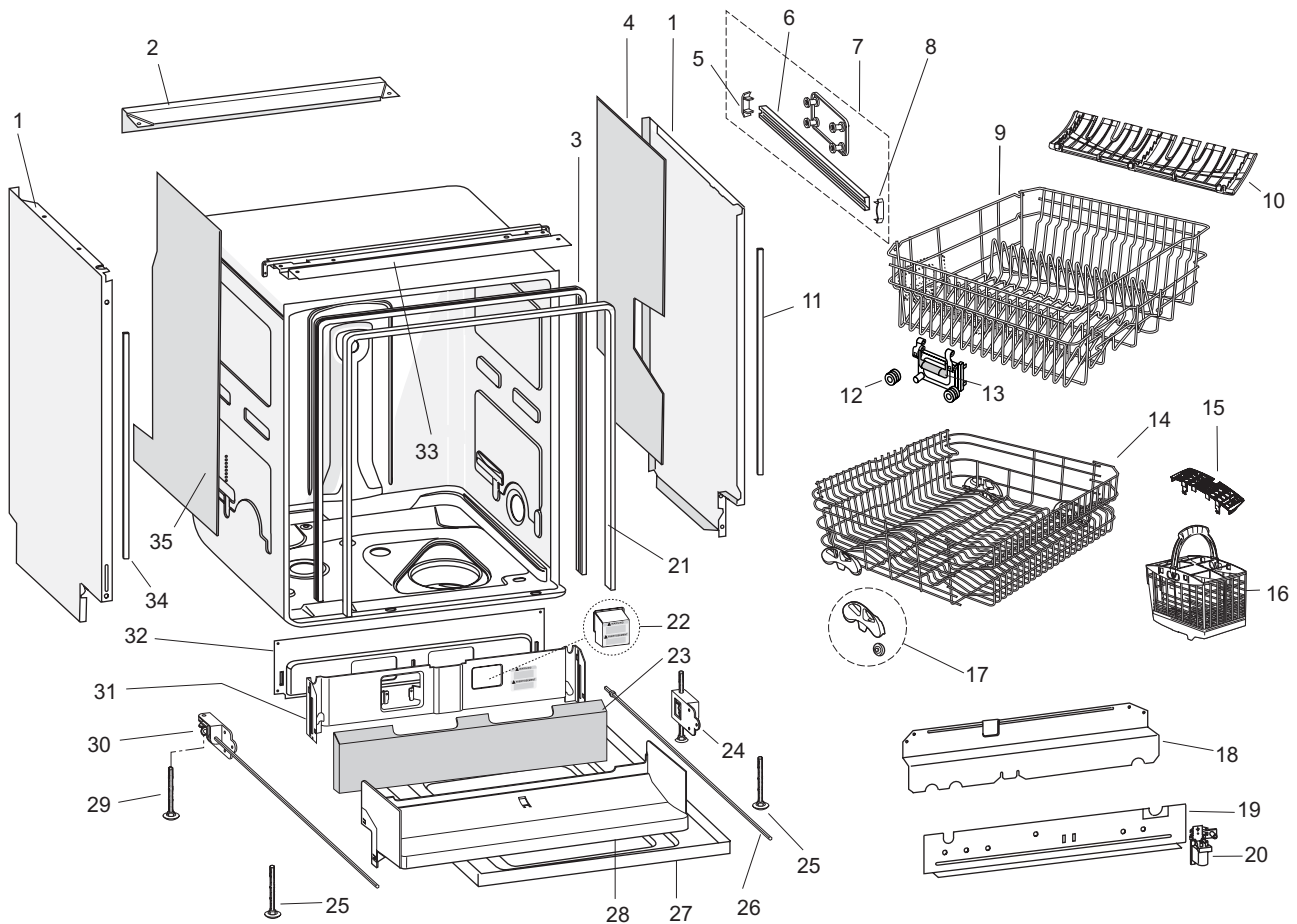

Item	Part #	Description	Item	Part #	Description
1	092835	Side Panel Kit, Left & Right	19	091601	Rear Support, Lower
2	033591	Rear Support, Upper	20	111621	Filter, Electronics
3	085019	Door Seal	21	054932	Support, Door Seal
4	076388	Insulation Panel, Right	22	112390	Electrical Box Cover
5	094117	Runner Clip, Rear	23	111645	Toe Kick (BK)
6	094116	Runner	24	092821	Leveling Assembly, Right
7	094112	Roller Assembly	25	092555	Leveling Leg, Front
8	094118	Runner Clip, Front	26	082476	Adjustment Rod
9	096978	Upper Rack	27	092554	Bottom Pan
10	096051	Shelve, Upper Rack (GY)	28	112344	Door Extension (BK)
11	111639	Filler Strip, Right (GY)	29	092822	Leveling Leg, Rear
12	109840	Roller, Upper Rack	30	092820	Leveling Assembly, Left
13	096052	Roller Assembly, Upper Rack	31	111638	Support, Toe Kick
14	096979	Lower Rack	32	091599	Access Panel, Front
15	087980	Silverware Basket Divider	33	079013	Door Spring Adjustment Panel Assembly
16	096055	Silverware Basket	34	111640	Filler Strip, Left (GY)
17	086474	Roller Assembly, Lower Rack	35	076387	Insulation Panel, Left
18	091600	Rear Support, Middle			

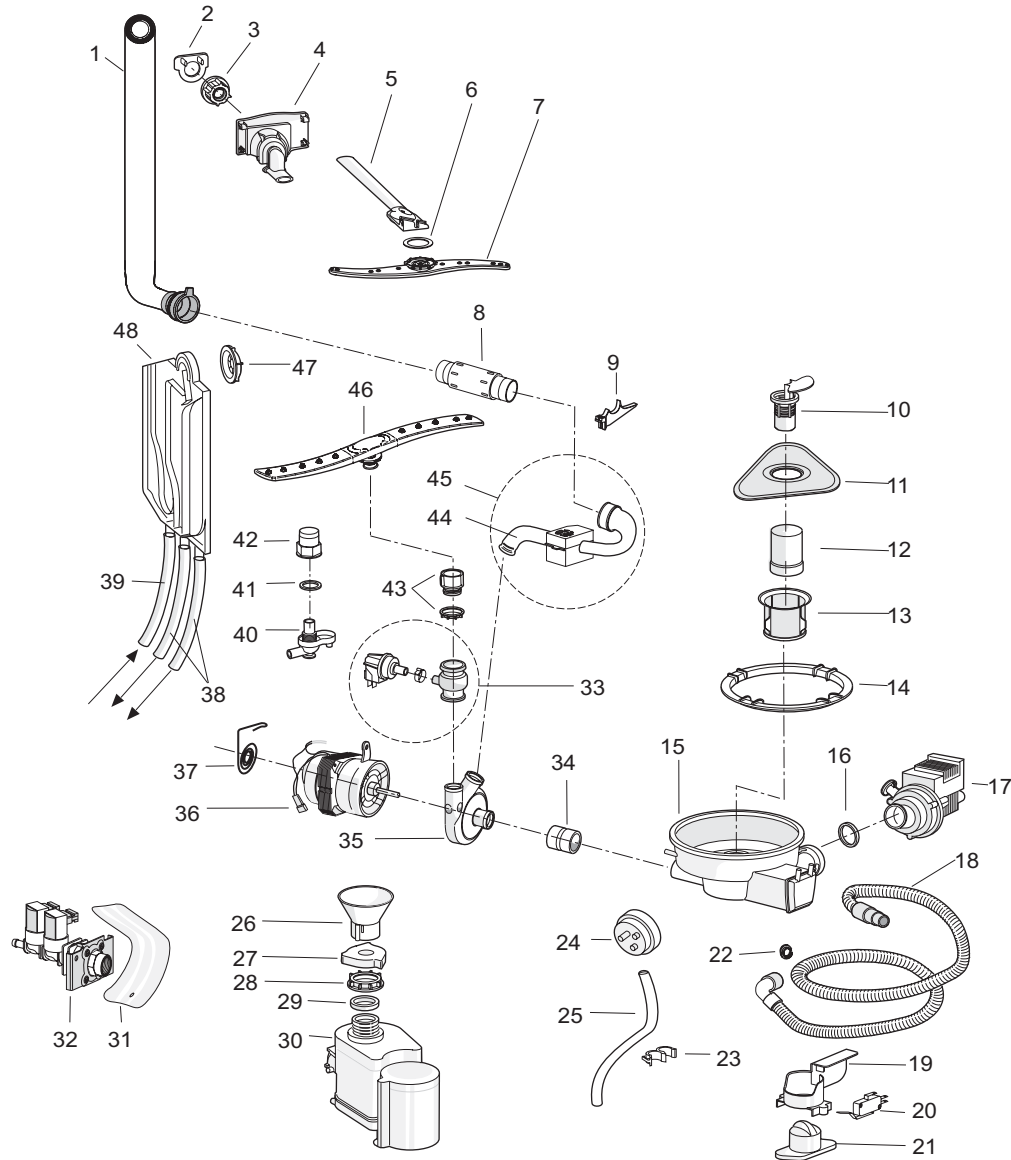

Item	Part #	Description	Item	Part #	Description
1	094152	Tube, Upper Arm Feeder	25	094154	Hose
2	054925	Rear Guide, Upper Rack	26	005819	Funnel
3	054862	Ring Nut	27	041088	Cap
4	110526	Feeder Assembly, Upper Spray Arm	28	041090	Retainer Ring
5	110527	Feeder Tube	29	084600	Gasket
6	098769	Gasket, Upper Spray Arm	30	111610	Water Softener
7	075746	Spray Arm, Upper	31	086801	Shield, Water Valve
8	111611	Flow Through Heater (1200w)	32	111609	Water Valve, Dual Solenoid
9	078394	Support	33	111631	Sensor Assembly, High Pressure
10	054863	Filter Basket	34	079016	Hose
11	054851	Filter Screen	35	055005	Main Pump
12	081164	Inner Filter	36	111606	Main Motor
13	061929	Fine Filter	37	076628	Support
14	054854	Sump Retainer Ring	38	054868	Hoses, Water Softener
15	094143	Sump	39	111855	Hose, Water Valve
16	054917	O-Ring, Drain Motor	40	094159	Overflow Sensor
17	111604	Drain Motor	41	075695	Gasket
18	111630	Drain Hose	42	094155	Cap
19	081162	Housing, Overflow Switch	43	075111	Locking Ring and Support
20	037205	Microswitch	44	091568	Hose
21	058843	Float	45	111613	Turbidity Sensor Assembly
22	054830	Retainer, Drain Hose	46	094182	Spray Arm, Lower
23	095801	Support	47	054927	Ring Nut
24	112062	Pressure Switch	48	110610	Water Inlet w/ Turbine

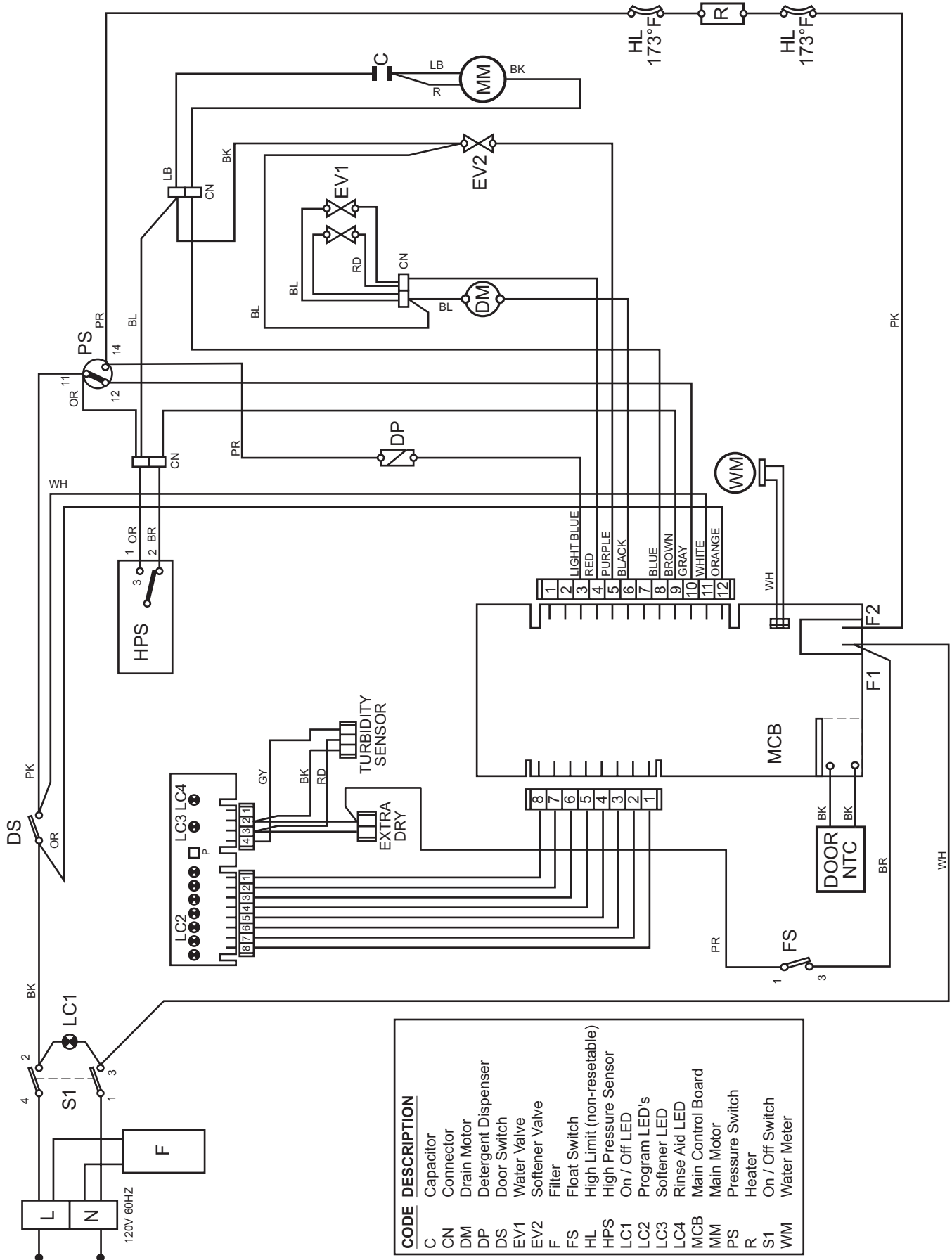

DISHWASHER MODEL					
L 63 LI 640	N/A	LL 64 LL 65	LI 670 LI 700		
NUMBER OF LED's					
4	5	6	7		
FLASHING LED FAULT CODE				FAULT	TROUBLESHOOTING
1 ■ □ □ □	2 □ ■ □ □ □	3 □ □ ■ □ □ □	4 □ □ □ ■ □ □ □	Float Switch	Water in Base Pan
1-2 ■ ■ □ □	2-3 □ ■ ■ □ □	3-4 □ □ ■ ■ □ □	4-5 □ □ □ ■ ■ □ □	No Drain	Drain Motor Disabled Filters Clogged Drain Hose Blocked
1-3 ■ □ ■ □	2-4 □ ■ □ ■ □	3-5 □ □ ■ □ ■ □	4-6 □ □ □ ■ □ ■ □	Main Motor Pressure Switch Blocked Filter	Main Motor Disabled Faulty Pressure Switch Filters Blocked
1-4 ■ □ □ ■	1-4 ■ □ □ ■ □	1-4 ■ □ □ ■ □ □	1-4 ■ □ □ ■ □ □ □	Control Board	Software of Control Board not Recognized. Run Test Program.
2 □ ■ □ □	3 □ □ ■ □ □	4 □ □ □ ■ □ □	5 □ □ □ □ ■ □ □	Water Valve	Water Valve Disabled
2-3 □ ■ ■ □	3-4 □ □ ■ ■ □	4-5 □ □ □ ■ ■ □	5-6 □ □ □ □ ■ ■ □	Fill Fault	Water Valve Disabled Turbine Disabled Control Board Faulty
2-4 □ ■ □ ■	3-5 □ □ ■ □ ■	4-6 □ □ □ ■ □ ■	5-7 □ □ □ □ ■ □ ■	Heating Element	Heating Element Disabled High Limit Open Control Board Faulty
3 □ □ ■ □	4 □ □ □ ■ □	5 □ □ □ □ ■ □	6 □ □ □ □ □ ■ □	NTC	NTC Defective or Not Positioned. Control Board Faulty.
4 □ □ □ ■	5 □ □ □ □ ■	6 □ □ □ □ □ ■	7 □ □ □ □ □ □ ■	NTC	NTC Defective or Not Positioned. Control Board Faulty.