

## REFRIGERATOR FEATURES AND SPECIFICATIONS

### ORIGINAL SIZE

MODEL:  
(21TF)

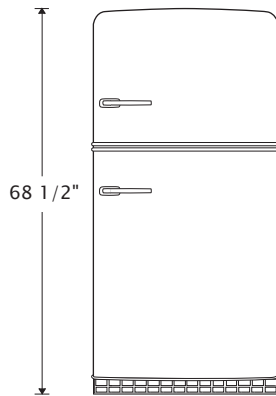
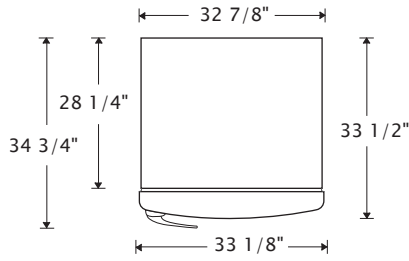

### RETROPOLITAN

MODEL:  
(19BF)

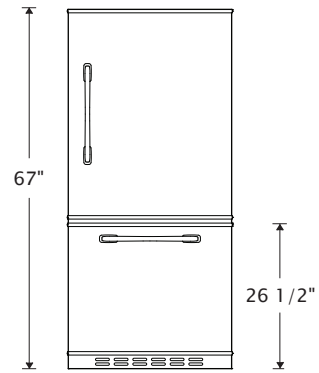
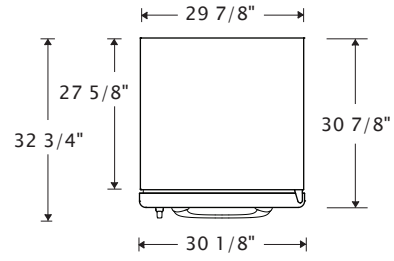

Total Capacity	20.5 cu. ft.
Refrigerator Capacity	14.4 cu. ft.
Freezer Capacity	6.2 cu. ft.
Clearance: Back	1/2"
Clearance: Side	1/4"
Side Clearance for door to open 90°	4 1/2"
Adjustable Rollers	Standard
Energy Guide (kWh/year)	436
Electrical	115V, 60Hz, AC only, 15 or 20 amp fused

**FEATURES:**

Stamped Metal Body, Chrome Trim, 2 Half-Width Clear Crisper Drawers, Gallon Door Storage, Temperature Management System, 1 Fixed Full-Width Freezer Shelf, 3 Easy-Clean Spill-Proof Glass Shelves, LED Interior Lighting, Optional Ice Maker, Available Left Hand Hinge, 2 Years Parts and Labor Warranty

Total Capacity	18.7 cu. ft.
Refrigerator Capacity	13 cu. ft.
Freezer Capacity	5.7 cu. ft.
Clearance: Back	1/2"
Clearance: Side	1/4"
Side Clearance for door to open 90°	3 1/2"
Adjustable Rollers	Standard
Energy Guide (kWh/year)	553
Electrical	115V, 60Hz, AC only, 15 or 20 amp fused

**FEATURES:**

Stamped Metal Body, Chrome Trim, Gallon Door Storage, 2 Half-Width Clear Crisper Drawers, Four Half-Width Adjustable Glass Shelves, Temperature Management System, Slide-Out Upper Freezer Basket, Glide-Out Freezer Basket with Organizer, Ice Maker, Available Left Hand Hinge, 2 Years Parts and Labor Warranty



## REFRIGERATOR FEATURES AND SPECIFICATIONS

### SLIM SIZE

MODEL:  
(11TF)

### STUDIO SERIES

MODEL:  
(14TF)

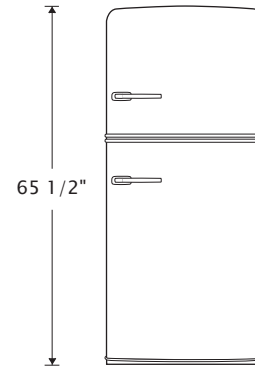
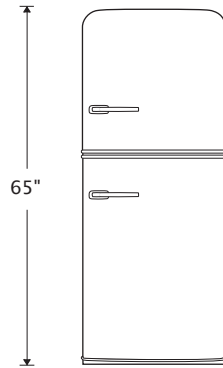
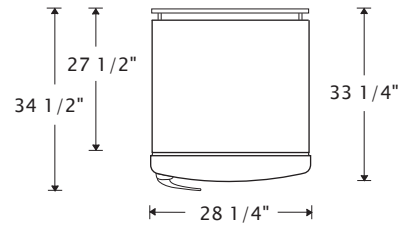
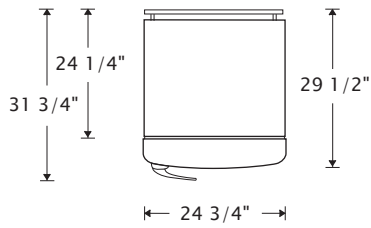

Total Capacity	11.6 cu. ft.
Refrigerator Capacity	8.6 cu. ft.
Freezer Capacity	3 cu. ft.
Clearance: Back	1/2"
Clearance: Side	1/4"
Side Clearance for door to open 90°	4 1/2"
Adjustable Rollers	Standard
Energy Guide (kWh/year)	345
Electrical	115V, 60Hz, AC only, 15 or 20 amp fused

**FEATURES:**

Stamped Metal Body, Chrome Trim, Full-Width Fixed Refrigerator Door Storage, Temperature Management System, Optional Ice Maker, Available Left Hand Hinge, 2 Years Parts and Labor Warranty

Total Capacity	14.4 cu. ft.
Refrigerator Capacity	10.6 cu. ft.
Freezer Capacity	3.8 cu. ft.
Clearance: Back	1/2"
Clearance: Side	1/4"
Side Clearance for door to open 90°	4 1/2"
Adjustable Rollers	Standard
Energy Guide (kWh/year)	373
Electrical	115V, 60Hz, AC only, 15 or 20 amp fused

**FEATURES:**

Stamped Metal Body, Chrome Trim, 2 Half-Width Crisper Drawers, Adjustable Shelving, Available Left Hand Hinge, Temperature Management System, Optional Ice Maker, 2 Years Parts and Labor Warranty



# REFRIGERATOR FEATURES AND SPECIFICATIONS

## BEVERAGE FRIDGE

MODEL:  
(BC55UCFS)

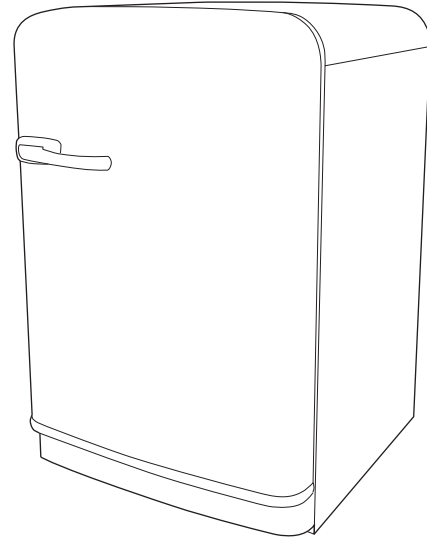
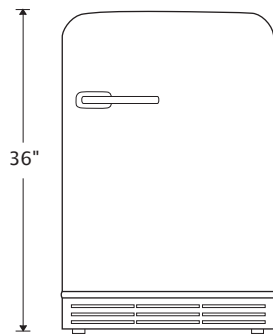
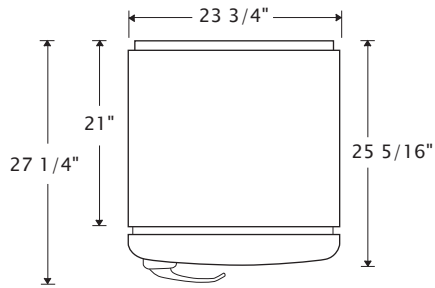

Total Capacity	5.5 cu. ft.
Refrigerator Capacity	5.5 cu. ft.
Clearance: Top	1/16"
Clearance: Back	2"
Clearance: Side	1/8"
Side Clearance for door to open 90°	4"
Adjustable Feet	Standard
Energy Guide (kWh/year)	307
Electrical	115V, 60Hz, AC only, 15 or 20 amp fused

### FEATURES:

Stamped Metal Body, Chrome Trim, Wine Rack, Opaque Crisper Drawer, Temperature Management System,  
3 Easy-Clean Glass Shelves, Available Left Hand Hinge, 1 Year Parts and Labor Warranty

## FEATURES AND SPECIFICATIONS

### DISHWASHER

MODEL:  
(DW24)

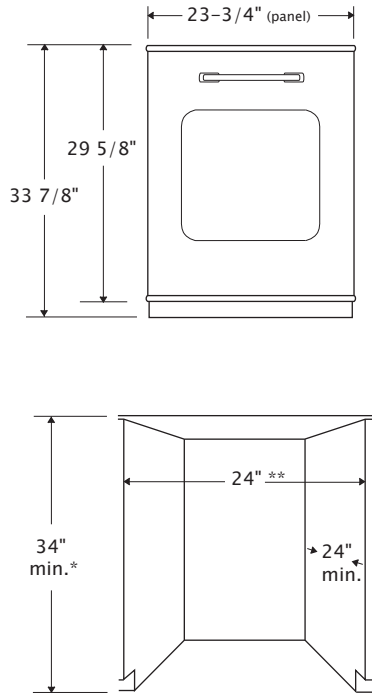

Capacity	16 Place Settings
Cycles	Auto, MixWash+, Pots and Pans+, Regular, GlassCare, Express Dry, Quick Wash
Cycle Options	Power Wash, Rapid Clean, Super Gloss, Sanitize, 1/2 Load, Time Delay
Energy Guide	225 (kWh/year) – Energy Star Rated
Warranty	2 Years Parts and Labor
Electrical	120 V, 60 Hz, AC only

**FEATURES:**

Stamped Metal Body, Authentic Chrome Trim, Stainless Steel Interior, 45dBA Ultraquiet Operation, 8 Wash Cycles and 6 Options, Full Size Third Rack, Energy Star Rated, Designed in Boulder, Colorado, Assembled and Shipped from Cedar Rapids, Iowa

\* Measured from the lowest point on the underside of countertop.  
\*\* Minimum, measured from narrowest point of opening.

### COUNTERTOP MICROWAVE

MODEL:  
(MICRO16)

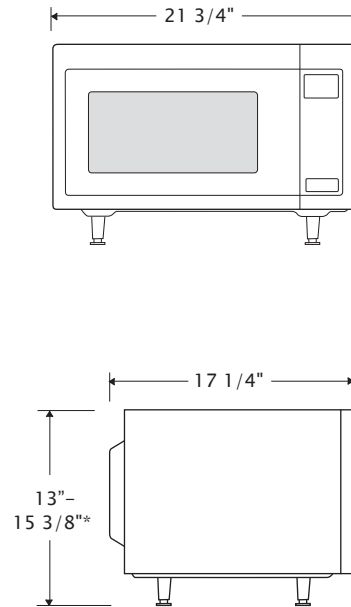

Capacity	1.6 cubic feet
Output Power	1200 Watts
Cooking Uniformity	13 1/2" Diameter Turntable
Warranty	2 Years Parts and Labor
Weight	38 lbs
Electrical	15 Amp, 120 V, 60 Hz, AC only.

**FEATURES:**

With up to 1,200 watts of cooking power, you'll have the power you need to prepare all types of food. Sensor cooking tracks the progress of your food and automatically adjusts cooking time as needed to deliver optimal results. A recessed glass turntable also makes cooking with larger items, like cooking bowls, easy so you can prepare caramel corn, party mix and soups in the microwave.

\*Microwave can be ordered with or without legs. Height will vary between 13"–15 3/8" depending on selection.

# INDUCTION COOKTOP FEATURES AND SPECIFICATIONS

## 30" Retro Induction Cooktop

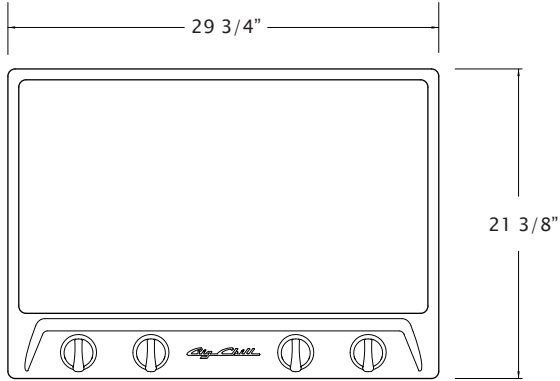

TOP VIEW

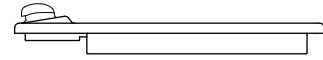

SIDE VIEW

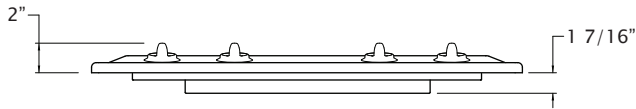
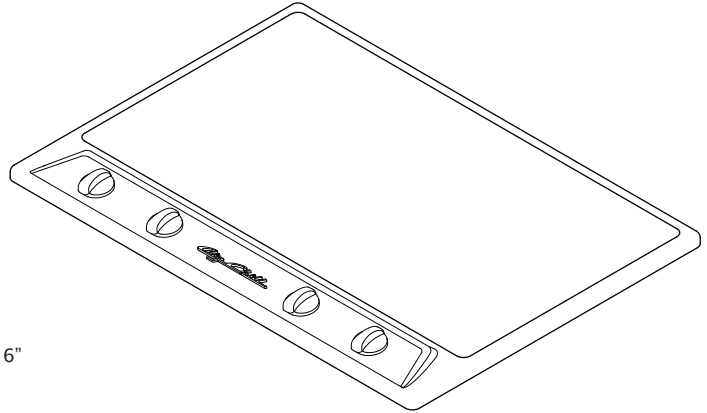

FRONT VIEW

Dimensions	2"H x 29 3/4"W x 21 3/8"D
Electrical	240/ 208 VAC, 40 Amps
	Max Power: 7400 W

### FEATURES:

9 Heat Levels, Power Booster, Boils a gallon of water in under 5 minutes, Large 9" induction elements provide up to 3,700 watts of cooking power per zone, Available in 8 standard colors and 200 custom colors

### INSTALL NOTES:

Allow 30"-36" between stove top and bottom of range hood (or per your local city codes).



*Big Chill*

# 30" GAS RANGE FEATURES AND SPECIFICATIONS

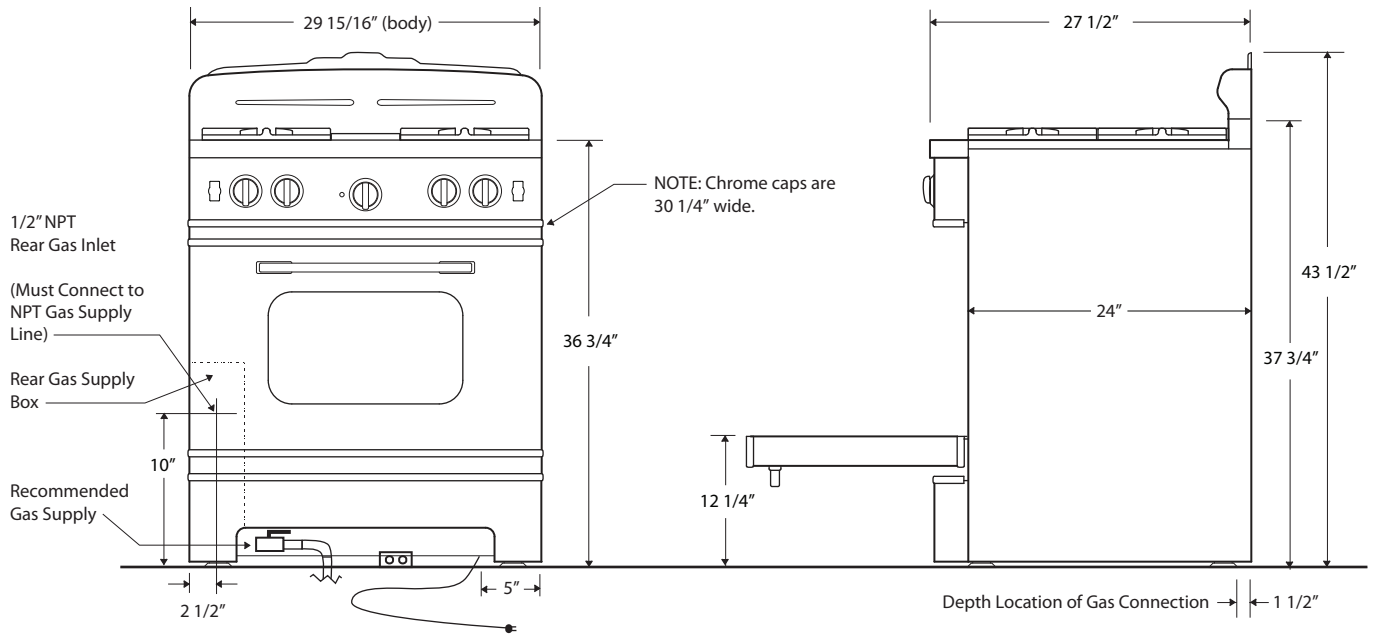

Front Burners	15,000 BTU	*Easy to clean Sealed Burner Top
Back Left Burner (Simmer)	6,000 BTU	*Automatic electronic ignition and re-ignition system
Back Right Burner	10,000 BTU	*24" depth for compatibility with standard kitchen cabinetry
Infrared Broiler Rating	15,000 BTU	*Convection fan
Oven Burner Rating	30,000 BTU	*Full Extension oven rack
Electrical Requirements	120 VAC, 15 Amps,	*Heavy-duty, commercial stainless steel construction
*(Unit must be on a non-GFI, dedicated outlet)	Single Phase	*2 Years Parts and Labor Warranty
Operating Gas Pressure	NAT: 5.0" WC LP: 10.0" WC	OVEN CAPACITY:
Install Clearance:	0" Side Cabinet 0" Back Wall 6" Side Wall	The cavity design of the oven provides the most precise temperature control, which delivers even heat distribution resulting in versatile performance. It has the largest oven capacity available on a 30" range and will accommodate a full-size commercial 18" x 26" baking sheet.

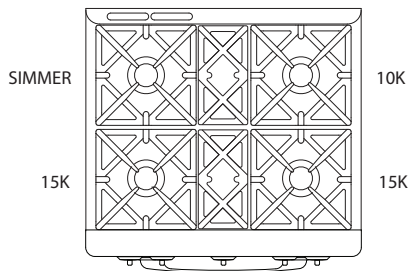

## INFRARED BROILER:

Because of its popularity in the commercial market, the direct-fired ceramic infrared broiler is standard on all residential ranges. The large burner produces 1850 F of intense, searing heat close to the burner, while effecting a gentler broiling for foods placed farther away. The broiler is fully recessed into the oven's top to create maximum cooking space.

## FULL MOTION GRATES:

Bring sauce to a boil while stirring on a front burner, then slide it to the rear to simmer while you saute up front! Our full motion grates allow you to easily reposition pots and pans from front to rear burners without lifting. The grates are also oversized to accommodate the largest stock pots and saute pans.



# 30" INDUCTION RANGE FEATURES AND SPECIFICATIONS

MODEL:  
BCR130

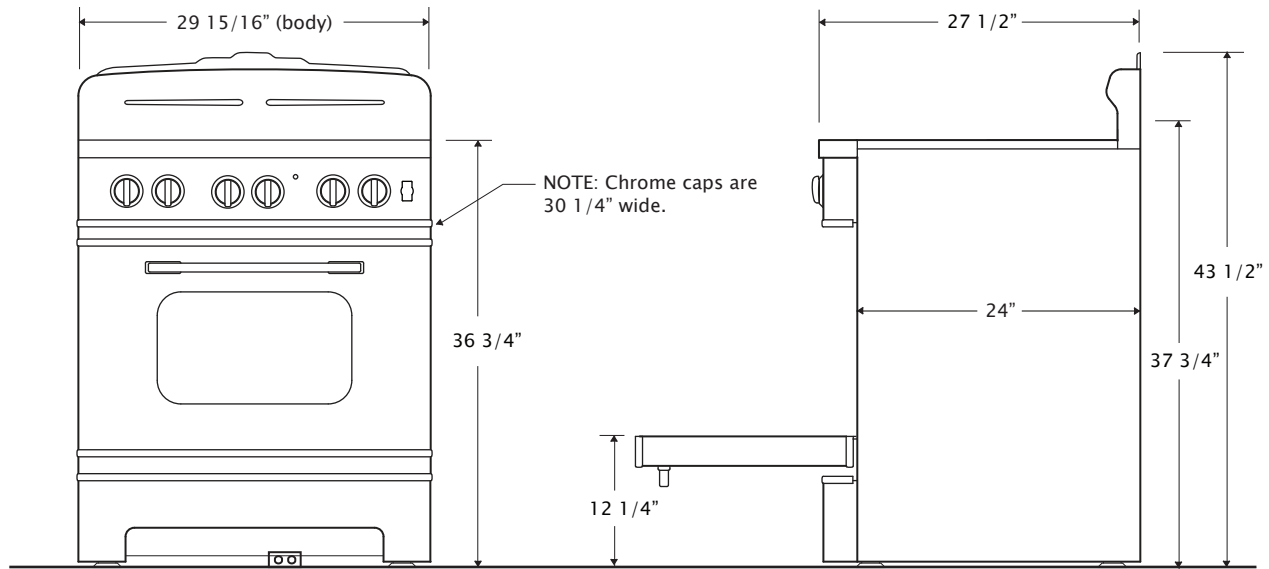

Front Left Burner	1850 Watts
Front Right Burner	1400 Watts
Back Left Burner	1850 Watts
Back Right Burner	2300 Watts
Broiler Element	2500 Watts
Oven Bake Element	2500 Watts
Oven Capacity	4 cu.ft.
Electrical Requirements	240 Volt, 60 Hertz,
*(Unit must be on a non-GFI, dedicated outlet)	50 Amp, Single Phase

- \*5 selectable cooking modes, including preheat
- \*Powerful 2500 watt top and bottom heating elements
- \*True convection mode with 1800 watt convection element
- \*Full Extension oven rack
- \*Heavy-duty, commercial stainless steel construction
- \*Easy to clean cavity
- \*2 Years Parts and Labor Warranty

Install Clearance:	0" Side Cabinet
	0" Back Wall
	0" Side Wall

**OVEN CAPACITY:**  
The cavity design of the oven provides the most precise temperature control, which delivers even heat distribution resulting in versatile performance. It has the largest oven capacity available on a 30" range and will accommodate a full-size commercial 18" x 26" baking sheet.

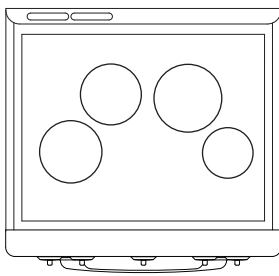

7.9" Diameter  
1850 W

8.6" Diameter  
2300 W

7.9" Diameter  
1850 W

6.3" Diameter  
1400 W

- INDUCTION COOKTOP:**
- \*4 cooktop induction zones that automatically adjust to the size of the pan
  - \*9 heat settings on each cooktop burner
  - \*\*"Power Booster" function that boils a gallon of water in less than 5 minutes!
  - \*\*"Heat Accelerator" function to kickstart the cooking process on all cooking zones
  - \*\*"Keep Warm" function allows two levels of even, low temperatures

- ROBUST SAFETY FEATURES:**
- \*\*"Knob Lock" function (knob can be electronically locked)
  - \*Pan detection technology: Unit won't start unless a pan is on unit
  - \*Hot surface indicator light to indicate when it's safe to touch



## 36" GAS RANGE FEATURES AND SPECIFICATIONS

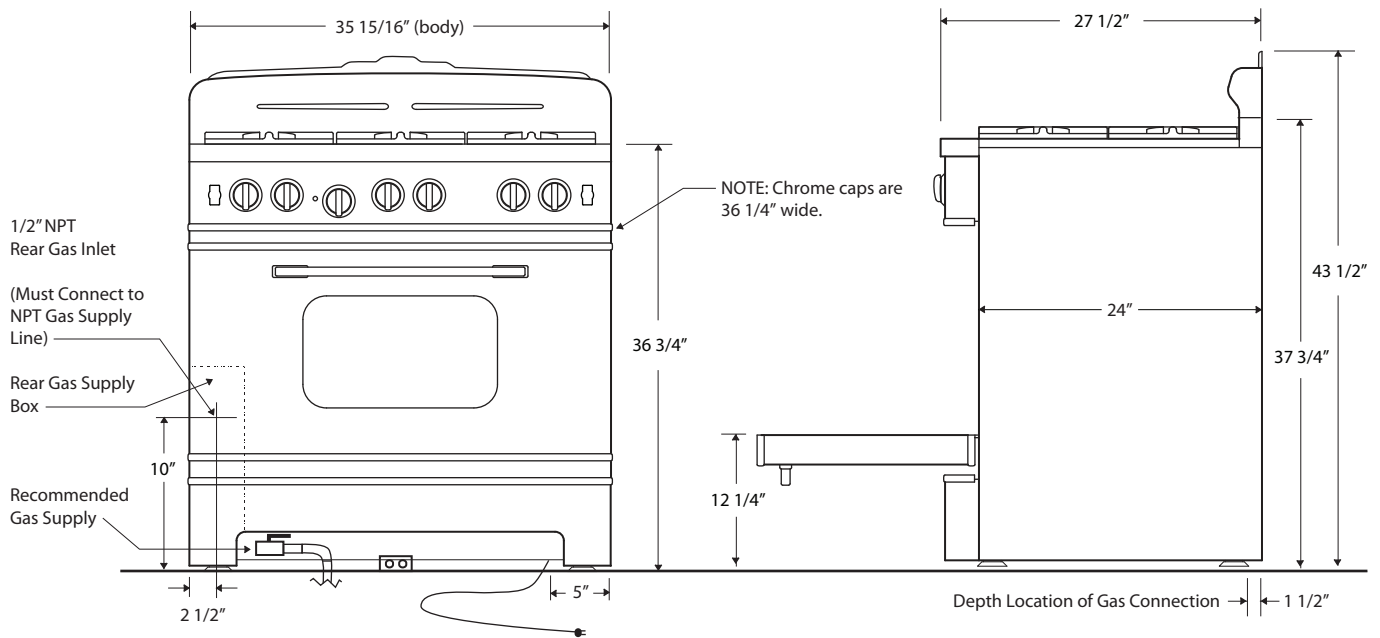

Front Burners	15,000 BTU	*Easy to clean Sealed Burner Top
Back Left Burner (Simmer)	6,000 BTU	*Automatic electronic ignition and re-ignition system
Back Right Burners	10,000 BTU	*24" depth for compatibility with standard kitchen cabinetry
Infrared Broiler Rating	15,000 BTU	*Convection fan
Oven Burner Rating	30,000 BTU	*Full Extension oven rack
Electrical Requirements	120 VAC, 15 Amps,	*Heavy-duty, commercial stainless steel construction
*(Unit must be on a non-GFI, dedicated outlet)	Single Phase	*2 Years Parts and Labor Warranty
Operating Gas Pressure	NAT: 5.0" WC LP: 10.0" WC	<b>OVEN CAPACITY:</b>
Install Clearance:	0" Side Cabinet 0" Back Wall 6" Side Wall	The cavity design of the oven provides the most precise temperature control, which delivers even heat distribution resulting in versatile performance. It has the largest oven capacity available on a 36" range and will accommodate a full-size commercial 18" x 26" baking sheet.

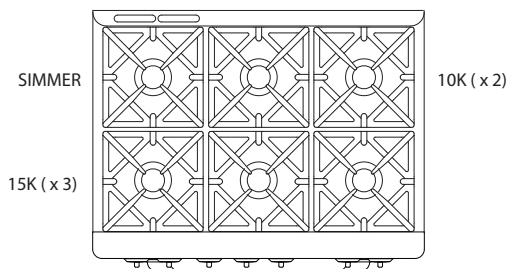

### INFRARED BROILER:

Because of its popularity in the commercial market, the direct-fired ceramic infrared broiler is standard on all residential ranges. The large burner produces 1850 F of intense, searing heat close to the burner, while effecting a gentler broiling for foods placed farther away. The broiler is fully recessed into the oven's top to create maximum cooking space.

### FULL MOTION GRATES:

Bring sauce to a boil while stirring on a front burner, then slide it to the rear to simmer while you saute up front! Our full motion grates allow you to easily reposition pots and pans from front to rear burners without lifting. The grates are also oversized to accommodate the largest stock pots and saute pans.





# 48" RETRO RANGE FEATURES AND SPECIFICATIONS

MODEL:  
BCR48

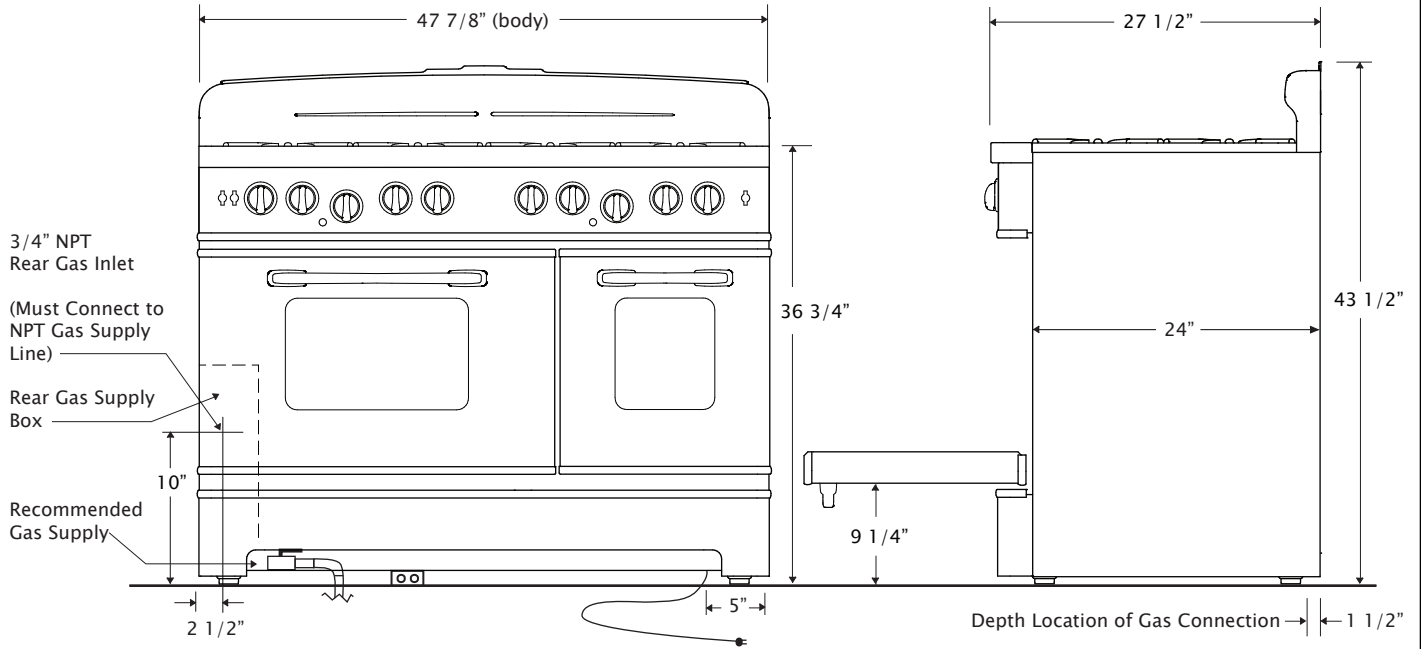

Front Burners	15,000–21,000 BTU
Back Left Burner (Simmer)	6,000 BTU
Back Burners	6,000–10,000 BTU
Infrared Broiler Rating	15,000 BTU
Oven Burner Rating	30,000 BTU
Electrical Requirements	120 VAC, 15 Amps,
*(Unit must be on a non-GFI, dedicated outlet)	Single Phase

- \*Easy to clean Sealed Burner Top
- \*Automatic electronic ignition and re-ignition system
- \*24" depth for compatibility with standard kitchen cabinetry
- \*Convection fan
- \*Full Extension oven rack
- \*Heavy-duty, commercial stainless steel construction
- \*2 Years Parts and Labor Warranty

Operating Gas Pressure	NAT: 5.0" WC LP: 10.0" WC
Install Clearance:	0" Side Cabinet 0" Back Wall 6" Side Wall

**OVEN CAPACITY:**  
The cavity design of the oven provides the most precise temperature control, which delivers even heat distribution resulting in versatile performance. It has the largest oven capacity available on a 48" range and will accommodate a full-size commercial 18" x 26" baking sheet.

**INFRARED BROILER:**  
Because of its popularity in the commercial market, the direct-fired ceramic infrared broiler is standard on all residential ranges. The large burner produces 1850 F of intense, searing heat close to the burner, while effecting a gentler broiling for foods placed farther away. The broiler is fully recessed into the oven's top to create maximum cooking space.

**FULL MOTION GRATES:**  
Bring sauce to a boil while stirring on a front burner, then slide it to the rear to simmer while you saute up front! Our full motion grates allow you to easily reposition pots and pans from front to rear burners without lifting. The grates are also oversized to accommodate the largest stock pots and saute pans.

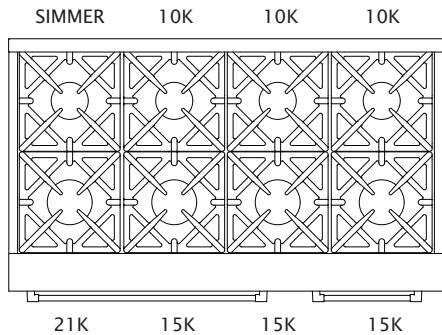

# RANGE HOOD FEATURES AND SPECIFICATIONS

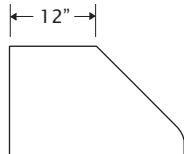
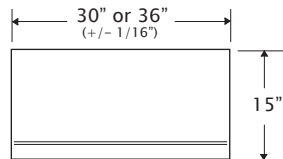
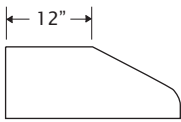
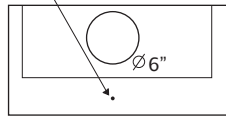
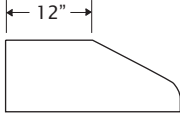
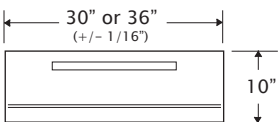
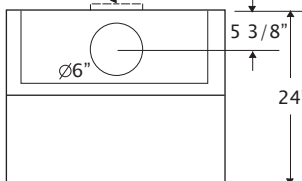
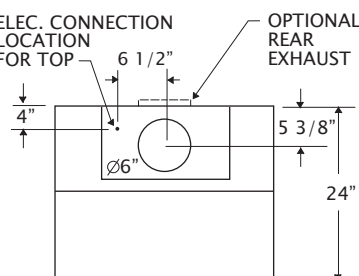
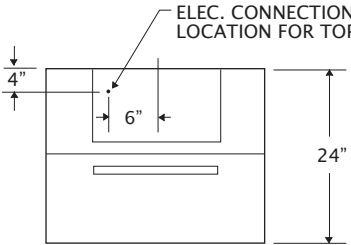
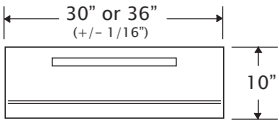
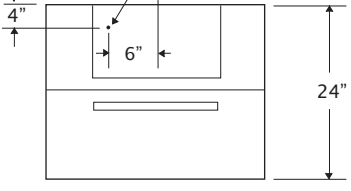
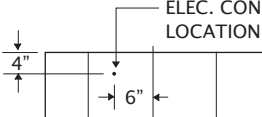
<b>15" Hood</b> <small>MODELS: (BCH3015) (BCH3615)</small>	<b>10" Hood</b> <small>MODELS: (BCH3010) (BCH3610)</small>	<b>10" Hood—RECIRCULATING</b> <small>MODELS: (BCH3010R) (BCH3610R)</small>
 <p style="text-align: center;">SIDE VIEW</p>  <p style="text-align: center;">FRONT VIEW</p> <p>OPTIONAL REAR EXHAUST</p>  <p style="text-align: center;">TOP VIEW</p> <p>ELEC. CONNECTION LOCATION</p>  <p style="text-align: center;">BACK VIEW</p>	 <p style="text-align: center;">SIDE VIEW</p>  <p style="text-align: center;">FRONT VIEW</p> <p>ELEC. CONNECTION LOCATION FOR TOP</p> <p>OPTIONAL REAR EXHAUST</p>  <p style="text-align: center;">TOP VIEW</p> <p>ELEC. CONNECTION LOCATION FOR REAR</p>  <p style="text-align: center;">BACK VIEW</p>	 <p style="text-align: center;">SIDE VIEW</p>  <p style="text-align: center;">FRONT VIEW</p> <p>ELEC. CONNECTION LOCATION FOR TOP</p>  <p style="text-align: center;">TOP VIEW</p> <p>ELEC. CONNECTION LOCATION FOR REAR</p>  <p style="text-align: center;">BACK VIEW</p>

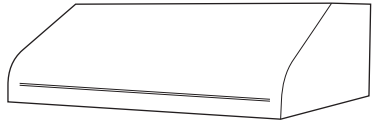

# RANGE HOOD FEATURES AND SPECIFICATIONS

## 12" Tall Bungalow Hood

MODELS:  
(BCH3012)  
(BCH3612)

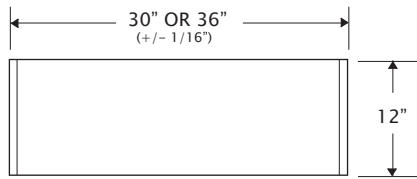

FRONT VIEW

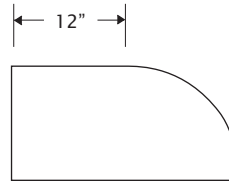

SIDE VIEW

OPTIONAL  
REAR EXHAUST

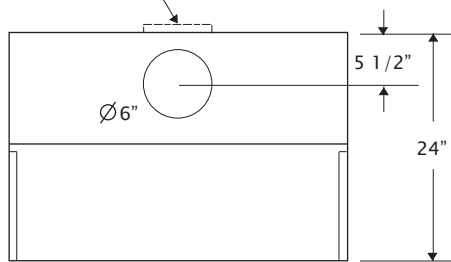

TOP VIEW

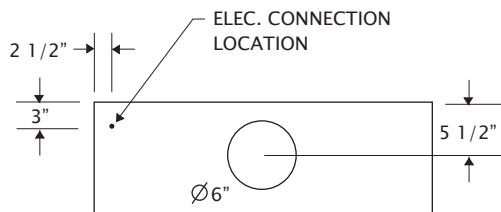

BACK VIEW

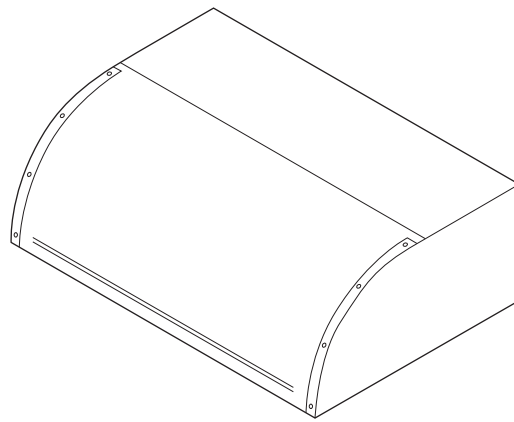

Dimensions	12"H x 30"W (OR 36") x 24"D
Vent	External, Reversible top or rear exhaust.
Blower	600 CFM / 3-Speed
Electrical	120 VAC, 15 Amps

### FEATURES:

Commercial grade 18 gauge 300 stainless steel construction, Welded seamless corners, Dishwasher safe stainless steel baffle filters, 3-Speed blower control, Halogen lamps with dimmer control, Largest filtered capture in the industry

### INSTALL NOTES:

Allow 30"-36" between stove top and bottom of range hood (or per your local city codes).

*Big Chill*

# WALL OVEN FEATURES AND SPECIFICATIONS

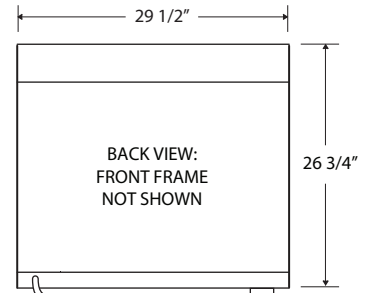
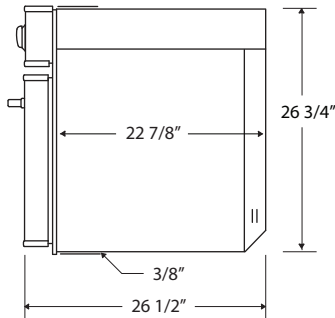
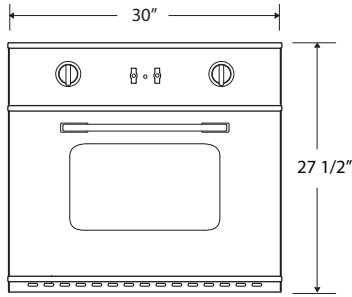

LOCATION OF ELECTRICAL CONNECTION. ATTACHED TO 20" FLEXIBLE CONDUIT.

## FEATURES

- \*4 cu.ft. Large Oven Capacity
  - \*2500 watt bake element
  - \*5000 watt broil element
  - \*Selectable convection mode
  - \*Coved corner interior with removable bottom for easy cleaning
  - \*Heavy duty, full extension oven racks
  - \*2 Years Parts and Labor Warranty
  - \*Traditional black/white stippled interior
  - \*Heavy-duty, stainless steel construction
- \*Can be installed in wall or island
  - \*800 watt rear element
  - \*Simple controls
  - \*Can be stacked to double capacity

## CABINET CLEARANCES

\*RECOMMENDED CABINET WIDTH IS 33"

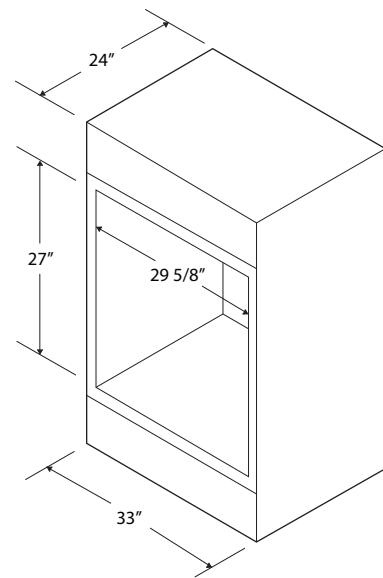

## Oven Capacity

The cavity design of the oven provides the most precise temperature control, which delivers even heat distribution resulting in versatile performance. It has the largest oven capacity available on a 30" range and will accommodate a full-size commercial 18" x 26" baking sheet.

## Electrical Requirements

240 Volt, 60 Hertz, 35AMPS, Single Phase  
 \*(Unit must be on a non-GFI, dedicated outlet)

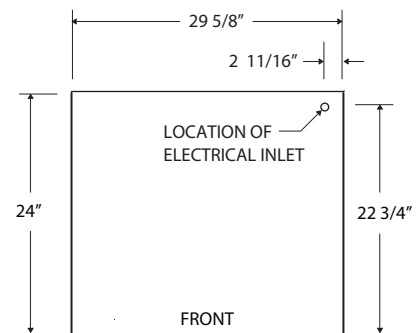

TOP VIEW CABINET

